

Avatar

HORSCH

Farming with passion

Avatar SD
Avatar SW

ROBUST, VERSATILE, PRECISE



Avatar

HORSCH OPENS A NEW CHAPTER IN NO-TILL FARMING

HORSCH have never lost sight of the products that for 30 years have been forming its reputation: the first Seed-Exactors left a permanent impression. If you go back to the beginning of the company, Michael Horsch at that time built a machine that was suitable for no-till farming.

The arguments at that time: disturb the soil as little as possible, encourage biodiversity and, of course, in the context of decreasing prices, save costs. Due to the opening of the eastern markets in the Nineties there suddenly was a large market for no-till farming equipment. However the pto-shaft driven technology could not be used for the large fields in the East.

With the experiences from the no-till sector Michael Horsch developed tine-based no-till technology for the eastern markets that is successfully sold there today. In the recent past, HORSCH thought about developing no-till technology based on disc coulters. It is not just suitable for the Latin American markets to disturb the soil as little as possible.

But also in other regions, too, the single disc coulters technology is of great interest – especially in Europe with increasing requirements in the sector of catch crops sowing to the sowing of main crops in catch crops or in regions that are faced with resistant weeds. In parts of Great Britain, Germany and France the farmers depend on new sowing technologies with reduced soil movement – a clear task for the **Avatar**.

The disc coulters technology plays an important role in large parts of Russia, Kazakhstan and China.

Good reasons for HORSCH to design our own **Avatar** line.



SD (SINGLEDISC) COULTER

ROBUST, VERSATILE, PRECISE

Robust

- Coulter pressure (up to 350 kg per coulters) is created via the well-proven rubber torsion system
 - No wear
 - No pivot points
 - Acts as a shock absorber (shocks from the coulters are not transferred to the machine)
- Long-life, maintenance-free bearings on all turning components for highest longevity and reliability
- Seed boot with carbide wear edges for increased service life and for safe scraping of earth from the seed disc even in most difficult conditions (cohesive soils, wet soils)

Versatile

- Suitable for all sowing conditions
 - Direct seed
 - Mulch seed
 - Conventional tillage
 - In standing catch crops
 - Stony soils
 - Very heavy, clayey soils
- Closing wheels for safe closing of the seed furrow for all sowing conditions
 - Rubber or steel version for the adaption to the soil conditions
 - Standard angle adjustment of the closing wheel
 - Aggressive for no-till farming or on very heavy soils
 - Passive on cultivated or very light soils
- Press wheel in the row guarantees optimum firming of the seed at the bottom of the furrow
 - Safe emergence even in dry conditions
 - High reliability even in very wet conditions due to integrated parking position for the press wheel; the press wheel then is moved away from the working range

Precise

- Stable depth control wheel for exact depth control of the coulters in changing or difficult soil conditions
- Wide depth control wheels in combination with a coulters pressure of max. 350 kg guarantee an exact placement of the seed in all sowing conditions
- The interaction of single disc coulters and seed shoe guarantees a safe opening of the furrow while at the same time harvest residues are removed from the furrow = optimum contact of seed and soil for quick and safe emergence



Steel closing wheel
Optional: steel or rubber closing wheel

Skid for seed placement

Fine adjustment of the sowing depth

Hydraulic coulters pressure
with central adjustment

Press wheel in the seed furrow for
optimum seed-soil contact of the grain

Avatar 6 SD

COMPACT AND VERSATILE

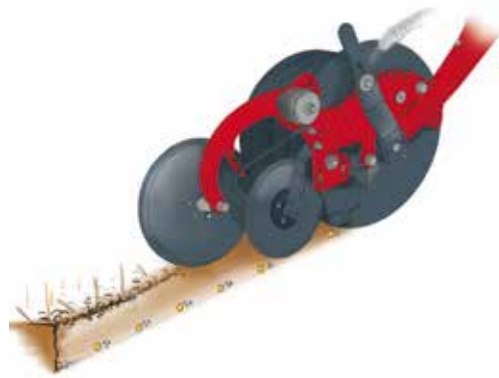

First row

Seed 1: e.g. coarse seed placed deeply



Second row

Seed 2: small grains, placed shallowly, e.g. incl. slug pellets

Machine concept

- Compact machine with a working width of 6 m
- 2-bar design with a row spacing of 16.7 cm and a clearance of 33.4 cm per row = reliability even with a lot of harvest residues resp. intensive catch crop population
- Large chassis tyres (standard: 600/55–26.5; optional: 710/50–26.5) for soil-saving work even with a full tank
- Light basic machine for sowing after conventional tillage or mulch seed
- Possibility to mount additional weights to guarantee a safe forming of the furrow and firming of the seed with the SingleDisc coulters even in most difficult conditions
- Standard with mechanic half-width shut-off
- Optional: electric half-width shut-off to be controlled via the ISOBUS terminal or automatic with SectionControl activation

Versatile hopper system

- Versatile with regard to the selection of the hopper system: single hopper and double hopper G+F (seed and fertiliser)
- Micro-granular unit for single and double hopper for metering of micro-granular, starter fertiliser, slug pellet or small grain seeds
- Seed distribution:
 - Even distribution to the two seed rows
 - Optional: distribution of different seeds from the double hopper to the two seed rows (e.g. product 1 to seed row 1; product 2 + micro-granular to both seed rows)
- Optimum placement of seeds with different grain sizes by adaption of the placement depth to the requirements of the respective seed (large grains – deep, small grains shallow)



Sowing with the Avatar (functions depending on the equipment)

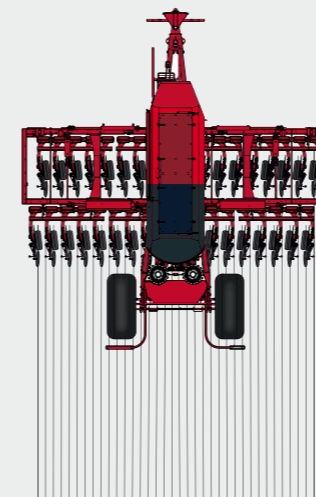

Sowing of all rows

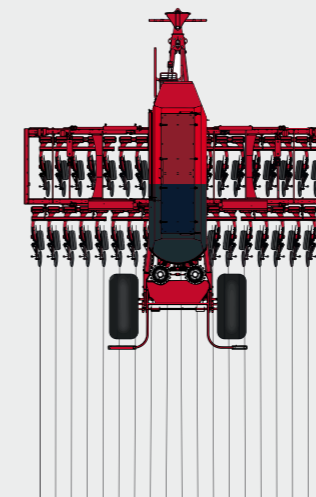

Sowing with double row spacing

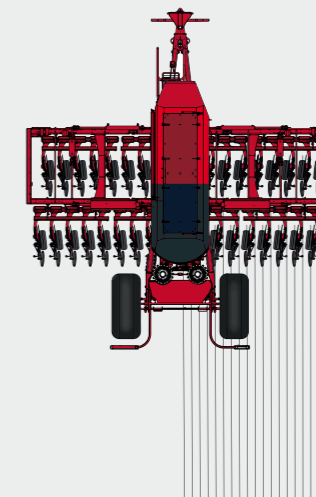

Half-width shut-off from the cabin

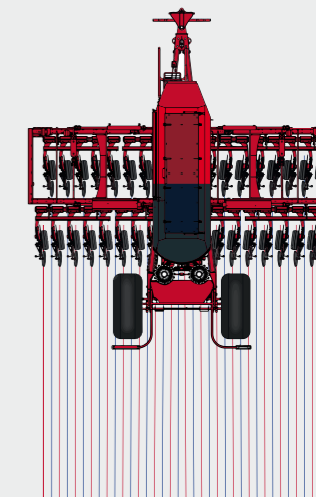

Sowing of two different products (e.g. red = shallow, blue = deep)

Johannes von Keiser

“We have been using the Avatar 6 SD on our 750 hectare since 3 years and our experiences are only positive. The heavy soils with a short rotation wheat/barley/rape encourage the development of weeds and black grass. To fight the black grass problem, we carry out a shallow cultivation after the harvest to make the weeds emerge. Before sowing the fields they are treated with glyphosate.

Then we use the Avatar with the large single disc seed coulters. It moves only little soil while sowing and minimises further emergence of weed. We noticed that with reduced tillage we can drive earlier into the fields after rain and that biodiversity increases. Moreover, we attach great importance to efficiency to be able to sow at the correct time. With all these advantages the 6-metre Avatar pays off quickly.”



Micro-granular unit



Optional: tyres 710/50–26.5 for maximum contact area



Double hopper 5 000 litre; partition 40/60



2-point linkage

Avatar 12 SD

COMPACT AND EFFICIENT



Versatile hopper system

3 components are metered independently and place in a seed band

Concept of the machine:

- Compact, manoeuvrable machine
- HORSCH seed waggon concept for maximum efficiency
- Seed waggon with a capacity of 5 800 litre; 50/50 partition seed/seed or seed/fertiliser
- Well-proven folding concept with compact transport dimensions; telescopic axle guarantees stability in the field, even in extremely hilly terrain and a maximum transport width of 3.00 m on the road
- Large tyres (520/85 R 38) at the seed waggon for maximum soil conservation and load-bearing capacity even in wet conditions
- Single-row design with SingleDisc coulters with row spacing of 25 or 30 cm

- Light-weight machine with integrated weight transfer and distribution to the coulter wings for homogeneous coulter pressure at all seed row to the very outside
- Low horsepower requirement due to little movement of soil
- Standard: mechanical half-width shut-off
- Optional: electric half-width shut-off to be controlled via the ISOBUS terminal or automatic with SectionControl activation (incl. micro-granular unit)

Versatile hopper system

- Double hopper with optional micro-granular unit
- Independent metering of up to 3 components (no de-mixing of seeds, exact metering seeds with different grain sizes)



Low Disturbance



Micro-granular unit: 300 litre



Standard telescopic axle
Compact transport width; reduction of the track pressure behind the tractor track



Compact in transport;
large working width in the field



Hydraulic weight transfer from the seed waggon to the coulter frame:
Regularly high coulter pressure over the whole working width.



Large tyres at the seed waggon:
520/85 R38



Jean Paul Kihm about the history of the project:

“During a meeting with Michael Horsch we talked about the problems on our farm. For quite some years already we are been having problems with the efficiency of plant protection agents with regard to black grass and ryegrass. Because of our problematic conditions we are forced to work with very short rotations wheat/barley/rape and a lot of winter crops, thus encouraging the development of weeds.

At the same time we were facing a second problem: A drinking water sample taken near some of our fields showed traces of plant protection agent residues. As a consequence the authorities told us to change our cultivation method. Based on these two problems – the increase of resistances and the demand to reduce our treatment frequency, we had to find a method to limit the emergence of weeds – and all that without any additional

plant protection measures. According to Michael Horsch a lot of farmers in Great Britain were facing the same problems. This is why we started to think about a seed drill that moves little soil and that leaves enough space to maybe carry out a mechanical measure later. It was to penetrate the soil in an optimum way and adapt perfectly to the terrain.

The basic idea of the **Avatar** was born. “The **Avatar 12 SD** was designed according to the ideas for French farmers, but it meets other requirements, too”, Jean Paul Kihm explains. “We wanted to continue to work efficiently and at the same time to reduce speed to guarantee a regular depth when placing the grains. The Avatar with twelve metre working width met these requirements to our entire satisfaction.”

Avatar SW

INNOVATIVE, EFFICIENT, WELL-PROVEN COMPONENTS

Concept of the machine:

- Maximum efficiency for large farms:
 - Working width 12 m
 - Seed waggon technology from the well-proven Pronto line
 - Designed for highest requirements and maximum efficiency during the season
- Seed waggon
 - Capacity of 12 000 litre for maximum efficiency
 - Hoppers 50/50 seed/seed or seed/fertiliser (application as G+F version, seed and fertiliser in one row)
- Low horsepower requirement due to reduced soil movement
- Manoeuvrable machine due to compact design
- Low horsepower requirement due to low machine weight



12 metre working width



Capacity of 12 000 litre with a 50/50 split hoppers



Solid monitoring sensors for seed and fertiliser



Compact design



2-bar coulters design for maximum clearance



Avatar SW on the road

ELECTRONICS INNOVATIVE AND DIGITAL SOLUTIONS



HORSCH Intelligence

The future machines think actively and HORSCH Intelligence makes it possible. With intelligent software and electronic solutions HORSCH seed drills work even more efficiently and help you to save both money and increase confidence.

HORSCH seed drill are always equipped with the ISOBUS standard. This does not only mean that every HORSCH machine can be controlled with any ISOBUS terminal. Additionally, SectionControl, VariableRate as well as the TaskController for data processing is a standard equipment for every HORSCH seed drill.

SectionControl

ISOBUS SectionControl allows for switching off individual sections automatically via GPS. The current position is determined, thus at field boundaries, on the headlands, in case of overlaps or in predefined areas individual sections (half-widths) or the whole working width is shut-off automatically.

When using a HORSCH Touch 800/1200 Terminal you can additionally use the MultiProduct function. This function independently switches on and off the application of fertiliser and seed. Without MultiProduct either fertiliser or seed can be switched on and off at the right time.

Advantages of SectionControl:

- Saving seed and fertiliser as overlaps on the headlands and at field boundaries are reduced to a minimum.
- Constant working quality on the whole field
- Productivity increase under various conditions (day and night, fog)
- Reduced stress for the driver
- Protection of the environment

VariableRate

ISOBUS VariableRate allows for a site-specific application of seed and fertiliser. Thus, with an appropriate application card for every section within a field the optimum quantity of fertiliser and seed can be applied. When using a HORSCH Touch 800/1200 Terminals you can additionally use the MultiProduct function. This function allows for independently varying the amount of fertiliser and seed. Without MultiProduct the application rate of either fertiliser or seed can be varied.

Advantages of VariableRate:

- Saving of seed and fertiliser as only the necessary quantity is applied
- Regular emergence due to optimum number of grains/m²
- Simple and quick documentation
 - The different application rates are documented automatically.
- Uncomplicated transmission to the acreage index
- Reduced stress for the driver
 - The optimum application rate is automatically used on the fields.
- Protection of the environment
 - Only the necessary amount of fertiliser is applied.

TaskController

The ISOBUS TaskController transfers data from the PC to the terminal in an uncomplicated way. It is also possible to transfer application rates, sown area and other data that were recorded while sowing from the terminal to the PC. This facilitates the administration of the acreage index. Via the integrated order management system orders can be created and executed.

Advantages of the TaskController:

- Uncomplicated data exchange
- Automatic documentation
- Structured working due to data management
- Simple administration of the acreage index
- Simple accounting and proof for contract services



HORSCH terminal



Touch 1200 Terminal



Touch 800 Terminal



TaskController

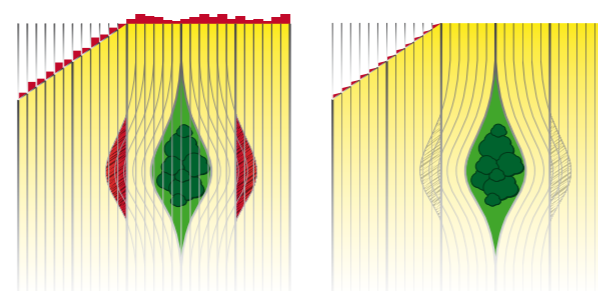

WITHOUT SectionControl

WITH SectionControl

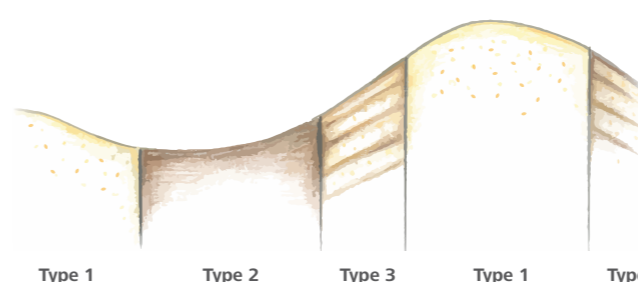

Type 1

Type 2

Type 3

Type 1

Type 3

Variable Rate takes different types of soil into account.



Soil quality	Seed	Fertiliser
high	300 grains/m ²	2,8 dt/ha PK
medium high	270 grains/m ²	2,5 dt/ha PK
medium low	250 grains/m ²	2,3 dt/ha PK
low	220 grains/m ²	2,0 dt/ha PK

VariableRate
Seed OR fertiliser

VariableRate with MultiProduct
Seed AND fertiliser

VariableRate allows for applying adapted quantities of fertiliser and seed on the basis of application cards.

TECHNICAL SPECIFICATIONS



HORSCH Avatar	12 SW
Working width (m)	12.00
Transport width (m)	4.36
Transport height (m)	5.28
Length (m)	11.65
Weight (kg)*	19 160
Seed hopper capacity double hopper (l)	12 000 (50:50, per 6 000 l)
Feed opening double hopper (m)	per 0.99 x 0.72
Filling height double hopper (m)	3.34
Number of seed coulters	60
Coulter pressure seed coulters (kg)	250
Seed coulters Ø (cm)	48
Closing wheels Ø (cm)	33
Depth control wheels Ø (cm)	40
Row spacing (cm)	20
Tyre size seed waggon	650/65 R 38
Tyre size seed unit	400/60-15.5
Working speed (km/h)	6-15
Horse power requirement (KW/hp) from	205/280
Double-acting control devices	3
Depressurized return flow (max. 5 bar)	1
Oil quantity hydr. fan (l/min)	60-80
Adj. drawbar linkage	Ring hitch Ø 55-73 mm
Ball-type linkage	K 80

* Weights of the machines in minimum equipment

HORSCH Avatar	6.16 SD	8.16 SD	12/40 SD
Working width (m/ft)	6.00	8.00	12.00/40 ft
Transport width (m)	2.89	2.98/3.50	2.98
Transport height (m)	3.06	3.98	3.80
Length (m)	6.64	---	8,31
Length single hopper/double hopper (m)	---	7.12/7.82	---
Weight (kg)*	9 300	---	18 880
Weight (kg)**	---	8 250	---
Seed hopper capacity single hopper (l)	3 500	3 500	---
Feed opening single hopper (m)	1.00x2.40	1.00x2.40	---
Filling height single hopper (m)	2.52	2.92	---
Seed hopper capacity double hopper (l)	5 000	5 000	5 800 (50:50, per 2 900 l)
Feed opening double hopper (m)	per 0.66x0.90	per 0.66x0.90	per 0.66x0.94
Filling height double hopper (m)	2.35	3.26	2.80
Hopper capacity micro-granular unit (l)	200	280	300
Number of seed coulters	36	48	48 – row spacing 25 cm 40 – row spacing 12” 32 – row spacing 15”
Coulter pressure seed coulters (kg)	250	250	250
Seed coulter Ø (cm)	48	48	48
Closing wheels Ø (cm)	33	33	33
Depth control wheels Ø (cm)	40	40	40
Row spacing (cm/inch)	16.70	16.70	25/15”/12”
Tyre size seed unit/waggon	600/55-26.5	600/55-26.5	520/85 R 38
Tyre size support wheels	---	---	15.0/55-17
Working speed (km/h)	6-15	6-15	6-15
Power demand (kW/HP)	155/210	---	220/300
Double-acting control devices	3	3	3
Depressurized return flow (max. 5 bar)	1	1	1
Oil quantity hydr. fan (l/min)	35-45	35-45	35-45
Lower link linkage	Cat. III + III/IV	Cat. III + III/IV	---
Adj. drawbar linkage	Hitch Ø 46-58 mm	Hitch Ø 46-58 mm	Hitch Ø 55-73 mm
Ball-type linkage	K 80	K 80	K 80

* Weights of the machines in minimum equipment

** Weights of the machines with minimum equipment with single hopper





www.horsch.com

Your distributor:

HORSCH

HORSCH Maschinen GmbH
Sitzenhof 1
92421 Schwandorf

Phone: +49 9431 7143-0
Fax: +49 9431 41364
E-Mail: info@horsch.com