

PA5570

5.5m (18' 0") reach

PA6070

6.0m (19' 8") reach

NEW



Machine Features

- » 5.5m and 6.0m reach
- » Left hand or Right hand build option
- » Choice of three-point or five-point axle-mounting
- » Parallel arm geometry
- » Hydraulic safety breakaway
- » Power Slew
- » 70hp High performance hydraulic system
- » Tapered, Seam welded arms
- » Hy-reach arm geometry
- » SoftStart Rotor Engagement (Electric rotor control only)
- » High capacity oil cooler
- » LED Road lighting kit
- » Integrated Debris Blower option
- » Choice of control systems
- » Choice of attachments

Markets

- » Agricultural
- » Governmental
- » Contractors

Tractor Requirements

- » 3500kg minimum tractor weight
- » 70hp minimum tractor horse power

Tractor Requirements		PA5570	PA6070			PA5570	PA6070
Min Horse Power Requirements	70hp	70hp	70hp	70hp	Minimum Tractor Weight	3500kg	3500kg
Machine Specification							
Maximum Reach	5.5m (18'0")	6.0m (19'8")	6.0m (19'8")	6.0m (19'8")	Power Arm Horsepower	70hp	70hp
Machine Weight*	1102kg	1380kg	1380kg	1380kg	Oil tank Capacity	200ltr	200ltr
Hydraulics							
Gear Semi Independent					Gear Totally Independent		<input checked="" type="checkbox"/>
Method of Attachment							
3-Point Linkage-Mounted		<input type="checkbox"/>			5-Point Axle Bracket-Mounted		<input type="checkbox"/>
Controls							
Cable Control					Xtra Touch Control - Mini (XTC - Mini)		
Switchbox		<input type="checkbox"/>			Xtra Touch Control		<input type="checkbox"/>
Monolever		<input type="checkbox"/>			REVOLUTION Control + EDS (Optional)		<input type="checkbox"/>
Machine Equipment							
Parallel Arm Geometry		<input checked="" type="checkbox"/>			Telescopic Dipper Arm		
Midcut Pack or VFR		<input type="checkbox"/>			Angle Float Kit - <i>Standard On Electric Models</i>		<input checked="" type="checkbox"/>
Lift Float Kit		<input type="checkbox"/>			Easy Drive System (EDS)		<input type="checkbox"/>
Oil Cooler		<input checked="" type="checkbox"/>			Power Slew		<input checked="" type="checkbox"/>
Safety Breakaway - <i>Hydraulic</i>		<input checked="" type="checkbox"/>			Cable Rotor Control - <i>Dual Rotation (Ti only)</i>		<input checked="" type="checkbox"/>
Road Lighting Kit		<input checked="" type="checkbox"/>			Electric Rotor Control - <i>Dual Rotation (Ti only)</i>		<input type="checkbox"/>
Warning Arrow - <i>Magnetic</i>		<input type="checkbox"/>			Window Guards		<input checked="" type="checkbox"/>
Cushioned Top Link		<input checked="" type="checkbox"/>			Debris Blower		<input type="checkbox"/>
Front Mounting Build					Orbitor Head Kit		<input type="checkbox"/>
Front Flap Kit		<input checked="" type="checkbox"/>			Flailhead Skid Kit		<input type="checkbox"/>
Hydraulic Roller		<input type="checkbox"/>			Flailhead Cushioned Grass Mowing Roller		<input type="checkbox"/>
Power Arm Attachments							
1.20m	Swingtrim Cutter Bar				1.50m	Omega Flailhead - <i>DD or BD</i>	<input type="checkbox"/>
1.50m	Swingtrim Cutter Bar				1.60m	Multicut Flailhead - <i>DD or BD</i>	<input type="checkbox"/>
1.50m	Sheartrim Cutter Bar - <i>SD</i>		<input type="checkbox"/>		1.60m	Omega Flailhead - <i>DD or BD</i>	<input type="checkbox"/>
1.60m	Sheartrim Cutter Bar - <i>MD</i>		<input type="checkbox"/>		2.00m	Multicut Flailhead - <i>DD or BD</i>	<input type="checkbox"/>
2.00m	Sheartrim Cutter Bar - <i>MD</i>		<input type="checkbox"/>		1.20m	Rotary Head - <i>FC - 2 Rotor</i>	
1.40m	Sheartrim Cutter Bar - <i>HD</i>		<input type="checkbox"/>		1.20m	Rotary Head - <i>MD - 1 Rotor</i>	<input type="checkbox"/>
2.20m	Sheartrim Cutter Bar - <i>HD</i>		<input type="checkbox"/>		1.50m	Rotary Head - <i>HD - 1 Rotor</i>	<input type="checkbox"/>
1.00m	Compact Supercut Flailhead - <i>GDD</i>				1.60m	Multisaw 1600	
1.20m	Supercut Flailhead - <i>DD</i>				2.00m	Multisaw 2000	<input type="checkbox"/>
1.20m	Multicut Flailhead - <i>DD or BD</i>		<input type="checkbox"/>		2.40m	Multisaw 2400	<input type="checkbox"/>
1.20m	Omega Flailhead - <i>DD or BD</i>		<input type="checkbox"/>		0.70m	Ditch and Grip Cleaner	<input type="checkbox"/>
1.50m	Multicut Flailhead - <i>DD or BD</i>		<input type="checkbox"/>				

Standard Equipment Optional Equipment Not Available

* depending on machine specification excluding attachment and oil

Control Options

The boxes that are ticked indicate the control options available for this Power Arm

<input checked="" type="checkbox"/>		<input checked="" type="checkbox"/>	
	Cable		Switchbox
<input checked="" type="checkbox"/>		<input checked="" type="checkbox"/>	
	Monolever		XTC - Mini
<input checked="" type="checkbox"/>		<input checked="" type="checkbox"/>	
	XTC		REVOLUTION

»» Choice of Controls



»» PA5570 Hedge Cutting



»» Orbital head Option

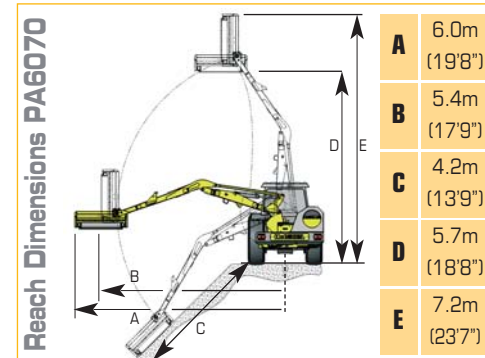

»» For illustration purposes only



»» VFR Arm-set Option