



For Earth, For Life  
**Kubota**

# BX

## KUBOTA DIESEL TRACTOR BX1880/BX2380 BX2680/BX23S

Four sub-compact diesel tractors with the versatility to do any job in your yard or on your property.

Now Available with a Kubota Swift-Tach Loader and Kubota Swift-Connect Backhoe



\*This information is sourced from overseas and may not necessarily apply locally. It is essential that you confirm specifications and other information with your local Kubota dealer.



**Easier operation, superior comfort, and new and simpler systems for attaching and detaching implements that let you switch jobs like a pro!**



Kubota invented the sub-compact diesel tractor so that even novices can comfortably and efficiently perform a variety of gardening, landscaping, and general property maintenance tasks. Now Kubota introduces the new BX80 Series, with improved operator comfort and the

new Kubota Swift-Tach Front Loader, you can quickly and easily remove the front loader without getting off the tractor. The BX23S comes equipped with Kubota's Swift-Connect Backhoe for all those digging jobs around the house and yard.

## **KUBOTA SUB-COMPACT DIESEL TRACTOR SERIES BX1880/BX2380/BX2680/BX23S**

# A sub-compact tractor with the power and versatility to handle a wide range of jobs.

Smaller than a full-size tractor and easier to operate, the sub-compact BX80 Series has the power and versatility to take on your toughest gardening, landscaping, and property maintenance jobs. A fuel-efficient 3-cylinder diesel engine provides plenty of power to haul, climb, and pull your way through even the most challenging tasks. The BX Series even makes maintenance easier with a bonnet that fully opens to provide quick access to all serviceable areas of the engine.



## COMPACT SIZE

BX-Series tractors are easy to drive and can work smoothly even in tight spaces. The BX-Series' compact size also means they're gentle on turf. But don't be fooled by their compact dimensions—these tractors are powerful and capable of handling a wide variety of chores and projects.

## PERFORMANCE-MATCHED KUBOTA DIESEL ENGINES

All the BX80 Series Tractors are powered by rugged engines built by Kubota exclusively for the BX Series. The BX1880 and BX2380/BX23S come with 18- and 23-horsepower diesel engines, while the BX2680 packs a 25.5-horsepower diesel engine under the hood. All three engines are 3-cylinder workhorses that offer power unparalleled for tractors this size...more than enough muscle to tackle even your toughest jobs.

## METAL BONNET / FENDERS

Strong and durable, the BX-Series' metal bonnet and fenders resist dings and dents, ensuring that your BX tractor continues to look as good as it performs.

## GROUND CLEARANCE

The BX-Series provides plenty of ground clearance - 210 mm for the BX1880, 226 mm for BX2380/ BX2680/BX23S - to get you over rocks and other objects in your path.

## VERSATILE CATEGORY I 3-POINT HITCH

The BX-Series feature a sturdy, hydraulically controlled Category I 3-point hitch that allows you to attach a wide variety of rear implements.

## ROPS HEIGHT

The BX80-Series has a ROPS height of less than 2,134 mm (except BX23S) so you can drive the BX through most standard garage door openings without folding down the ROPS.

## FULL OPEN BONNET



- A. QUARTER-INCHING VALVE
- B. BRIGHT HALOGEN HEADLIGHTS
- C. FRONT IMPLEMENT CONTROL VALVE
- D. REVERSE AIR FLOW
- E. LARGE FUEL TANK
- F. 4WD

## TWIN WORKLIGHTS (Optional)



**BX1880: 193 mm**  
**BX2380/BX2680**  
**BX23S: 213 mm**





# More control, more comfort, more space.

The redesigned instrument panel is more modern and stylish. It features familiar, easy to read indicators that display all the information you need to safely and efficiently operate your BX Series tractor. A fully padded high-back reclining deluxe seat with adjustable armrests, a new tilt steering wheel, and more legroom on the deck help keep you working at maximum efficiency and in maximum comfort.



## HIGH-BACK RECLINING DELUXE SEAT

A new deluxe seat helps keep the operator working comfortably and efficiently, even on the most demanding of tasks. The high-back reclining seat is fully adjustable and equipped with adjustable armrests. Soft cushioning supports the back and legs for optimum operator comfort. (Except BX1880/BX23S)

## EASY TO READ INSTRUMENT PANEL

The new BX80 Series' instrument panel offers easy to read indicators for all of the vital information you need to keep your tractor running smoothly, safely, and efficiently. A single glance at the redesigned instrument panel tells you everything you need to know about the major functions and condition of your BX80 Series tractor. The large tachometer in the center features a convenient orange indicator for the optimum rpm range for loader/backhoe operations.

## NEW TILT STEERING WHEEL

Repositioned for greater comfort and steering control, the BX80 Series steering wheel also tilts to accommodate operators of all shapes and sizes. (Except BX1880)

## CRUISE CONTROL

Cruise control automatically maintains a constant speed, letting you take your foot off the forward pedal. It's the easy way to mow large areas or travel long distances. (Optional on BX1880)

## EASY-TO-USE HST TRANSMISSION

HST offers fast and smooth forward and reverse speed and direction changes via twin foot pedals that leave your hands free for steering and implement control.

## SPACIOUS OPERATOR AREA

Operator comfort has been enhanced by a fully flat deck layout with the brake on the left side, providing more room for your feet. The new design also improves operability.

A. HYDRAULIC POWER STEERING

B. LEFT-SIDE BRAKE PEDAL

C. FULLY FLAT FLOOR FOR INCREASED LEGROOM

D. CUP HOLDER

E. HAND RAIL

F. 12V SOCKET & STORAGE COMPARTMENT



G. DELUXE LEVER GUIDE

H. TOOL BOX (Optional)

I. FOLDABLE ROPS

# New Easy-Over decks in 54" and 60" sizes.

Kubota's Easy-Over mid-mount mower decks are available on BX Series tractors. Easy-Over decks can be quickly and easily attached and removed. First, slide out the 40-degree ramps and release the rear spring-loaded wheels. Next, drive over the deck. Engage the Rear Deck Lock and the one-touch universal joint lever. Finally, retract the ramps, raise the deck, and start mowing!



## Step 1:

Slide out the ramps and release the gauge wheels.



## Step 2:

Drive over the deck.



## Step 3:

Lock the deck in place with the easy to use Rear Deck Lock.

### CLASS-LEADING DRIVE-OVER MOWER DECK GROUND CLEARANCE

The Easy-Over mid-mount mower deck features a full 152 mm of transport ground clearance — best among sub-compact tractor drive-over mower decks. Class-leading ground clearance means much better clearance over otherwise damaging obstacles.



### DRIVE-OVER MOWER ATTACHMENT KIT (Optional for BX23S)

This optional drive-over mower attachment kit lets you attach either the 54" or 60" Easy-Over mower deck to your BX23S tractor.

*\* Prototype version of mower deck shown in photos above.*



# KUBOTA EASY-OVER MID-MOUNT MOWER DECK RCK54D-26BX-1/RCK60D-26BX-1



## Step 4:

Connect the PTO shaft using the easy one touch lever and set the gauge wheels.



**Step 5:**  
Retract the ramps,  
raise your deck, and  
you're ready to go!

*Prototype version of mower deck shown in photos above.*

## Easy to drive, easy to manoeuvre.

The versatile BX Series tractors are easy to drive and manoeuvre, letting you take on the most challenging mowing jobs with confidence and efficiency. BX Series tractors slip easily between trees and other tight places in the yard. Their compact size also means they're gentle to the turf. The Easy-Over mid-mount mower deck is quick to attach and detach, and is available in two sizes—54" and 60"—to match your specific mowing needs.



# MID-MOUNT MOWER

## STANDARD DECK

This 3-blade mower offers a wide cutting area, allowing you to cut more grass in a single pass. Available with a 54" deck for the BX1880 or a 54" /60" deck for the BX2380/BX2680/BX23S.

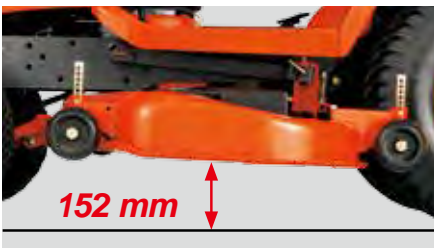
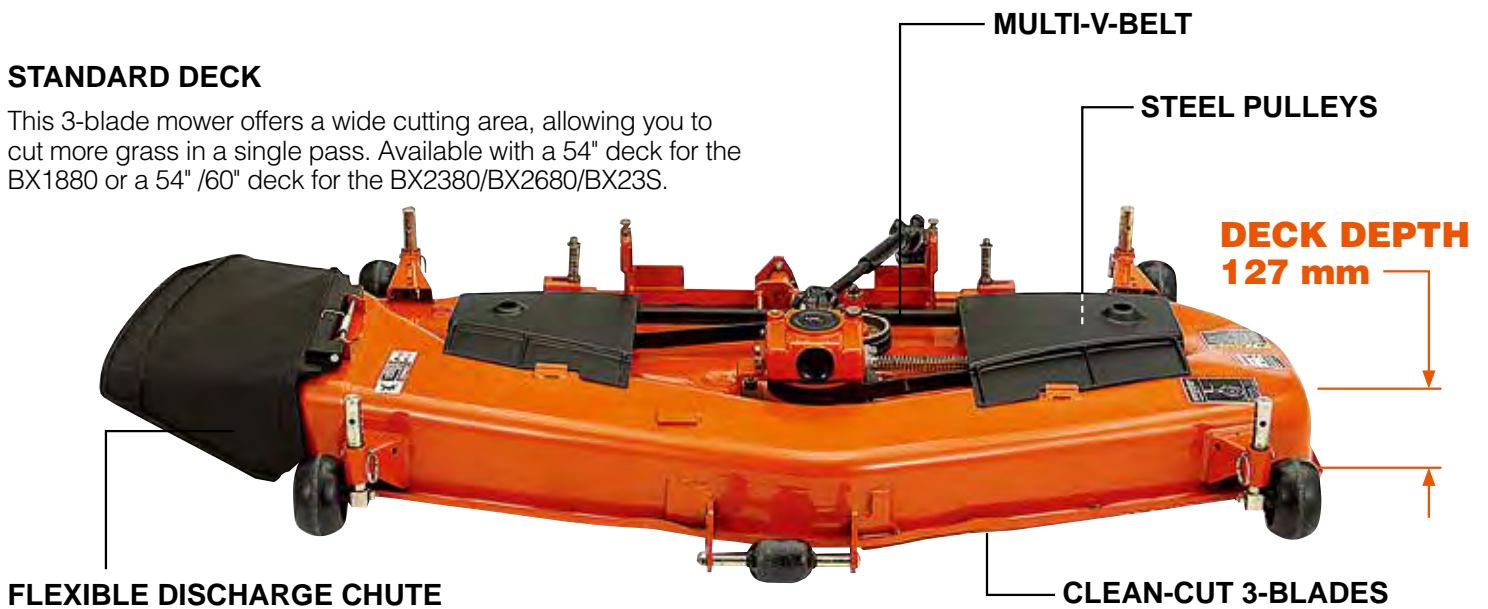

## HIGH CLEARANCE

With 152 mm of clearance – more than any other tractor in their class – the BX-Series tractors easily travel over uneven ground and protruding obstacles.



## MOWING-HEIGHT ADJUSTMENT DIAL

A simple twist of the dial adjusts the mower height in 1/4" increments to your desired cutting level.



## DURABLE SHAFT DRIVE

The BX Series' shaft drive delivers power smoothly from the mid-PTO to the mid-mount mower. Unlike belt drives, there is no slippage and maintenance is minimal.



## EASY ATTACH/ DETACH

The mower can be attached and detached quickly and easily—saving you time and effort.

# Faster, simpler attachment of implements.

Attaching and detaching the front loader couldn't be easier! Kubota's new Swift-Tach Loader system lets you do it without getting down from the tractor! To detach the front loader, simply follow the four steps and then back away. Reattaching the front loader is just as simple and convenient: just follow the steps in reverse order.



## CURVED FRONT LOADER BOOM

The BX's rounded boom perfectly complements the new overall tractor design. But its benefits don't end there. It also offers greater visibility.

## HOSE PROTECTION

The loader hoses are tucked inside the boom for greater protection and better operator visibility.



## FRONT GUARD (Optional/Standard with loader)

## LEVEL INDICATOR (Optional)

## FRONT AXLE CAPACITY

The BX-Series' front axle is built for serious heavy-lifting work like hauling loaded buckets of materials

## SIMULTANEOUSLY ATTACH AND DETACH ALL FOUR HYDRAULIC LINES

The BX80 Series features a new system for attaching and detaching all four hydraulic lines at the same time, making it even faster and easier to attach and detach the front end loader. The no-spill type coupler helps keep your tractor's frame clean and oil-free.



## Kubota Swift-Tach Loader

Four simple steps, performed from your seat, is all it takes to attach and detach the front loader.



**Step 1:** Lift the loader boom and fully dump the bucket. Pull stand release lever to lower the front loader stand. Reposition the bucket so that it is in slightly dumped (20 degrees dump position) and lower the boom until the front axle is off the ground.

# FRONT LOADER

## Kubota Swift-Tach Loader



**Step 2:** Unlatch the loader latch levers to detach the front loader hooks.



**Step 3:** Use the loader lever to remove the loader frame from the mast. Turn off the engine and move the loader joystick lever to relieve the hydraulic pressure.



**Step 4:** Pull one lever to quickly and easily detach the hydraulic lines as a unit and store the coupler on the loader boom.

**Back away and now you are done!**

# BX23S **Already ready to meet all of your needs around your property.**

From the moment you bring it home, the BX23S is ready to go to work loading, mowing, digging, and more. It comes with a performance-matched and fully integrated backhoe and front loader as standard equipment. Kubota's new Swift-Connect and Swift-Tach systems let you quickly and easily attach the backhoe (Swift-Connect) and front loader (Swift-Tach). A heavy-duty reinforced frame provides the durability, stability, and strength to complete any tough task.



## SIMULTANEOUSLY ATTACH AND DETACH ALL FOUR HYDRAULIC LINES

The BX80 Series features a new system for attaching and detaching all four hydraulic lines at the same time, making it even faster and easier to attach and detach the front end loader. The no-spill type coupler helps keep your tractor's frame clean and oil-free.



## FRONT GUARD

The stylish new front guard has been redesigned to fold downwards for easier opening of the bonnet.



## EASILY ATTACH/DETACH SWIFT-TACH LOADER

Kubota's 4-step Swift-Tach Loader mounting system simplifies the attachment and detachment of the front loader without getting off the tractor. No tools required!

## FOLDABLE ROPS

The BX23S's Rollover Protective Structure (ROPS) quickly folds without tools, letting the BX23S easily pass under low obstructions. It also makes storage in a garage or shed a snap.

*(Note: Kubota recommends that the ROPS be in the up position during most operations.)*

## LEVEL INDICATOR (Optional)

## HOSE PROTECTION

## CURVED FRONT LOADER BOOM

## THIRD FUNCTION VALVE (Optional)

The optional 3rd function valve broadens the scope of the front loader operation by enabling use of a grapple bucket. The 3rd function valve can be activated with buttons located on the grip of the joystick.

## BOLT ON CUTTING EDGE (Optional)

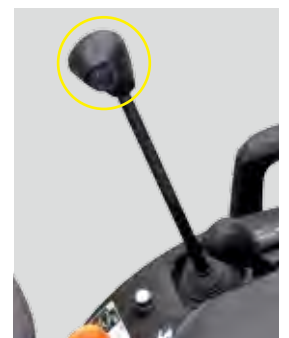

# Convenience and performance in a compact backhoe.

It may be compact, but the BX23S's backhoe offers jumbo size convenience and performance. It features a spacious, comfortable operator station with ample legroom, as well as a curved boom, 20° angle of departure, hydraulic hose protection, wide sight lines, and the Kubota Swift-Connect mounting system for quick and simple attachment/detachment of the backhoe. It's the ideal combination of convenience and performance for all your digging jobs.

## WIDE VIEW

Tucking the hydraulic hoses inside the backhoe boom provides two great benefits—protection for the hoses and greater visibility for the operator.

## CURVED BOOM

A curved boom not only allows you to dig deeper without contacting the edges of the excavation area, it also increases lifting height.

## MECHANICAL THUMB (Optional)

A positionable mechanical thumb gives the BX23S the ability to grasp and move logs, landscaping materials, and other items with ease, greatly expanding the types of jobs you can do around your property.



## REVERSIBLE SEAT

When it's time to switch from using the tractor or loader to using the backhoe, simply lift the reversible seat and swivel it to the back. The seat also can be adjusted forward and backward for optimal operator comfort.

## BOOM AND SWING CYLINDER CUSHION VALVES

Standard on the BX23S, an integrated cushion valve ensures smooth movement both horizontally and vertically, minimizing the shock that's transmitted to the operator when the backhoe arm hits its range limits.

## NO-SPILL COUPLER

The backhoe uses the same No-Spill coupler system as the front loader to keep your backhoe clean and oil-free.

## KUBOTA SWIFT-CONNECT

A simple lever operation is all it takes to quickly detach the backhoe from the BX23S, letting you drive away. To reattach, just back the BX23S into the backhoe and let the auto-lock mechanism secure them together.





# BACKHOE

## Kubota Swift-Connect Backhoe



### 20° ANGLE OF DEPARTURE

Steep inclines pose no problem for the BX23S, thanks to its 20° angle of departure. It also means the tractor can be loaded onto trailers with the backhoe mounted.



### PROTECTED HOSES

Tucking the hydraulic hoses inside the backhoe boom helps protect them from damage and the elements, thereby increasing their service life.



### LEVER BOOTS

Boots at the bottom of the backhoe levers help protect the operating mechanisms from the elements as well as ensure smoother operation and longer service life.



### MORE LEGROOM

Wide steps on each side of the boom controls provide more room—and comfort—for the operator's legs and feet.

# SPECIFICATIONS

Model		BX1880	BX2380	BX2680	BX23S
<b>Engine</b>		Liquid-cooled, 3-cylinder diesel			
Type		Liquid-cooled, 3-cylinder diesel			
Model		Kubota D722	Kubota D902	Kubota D1005	Kubota D902
Engine gross HP at 3200 rpm*1	HP (kW)	18.0 (13.4)	23.0 (17.1)	25.5 (19.0)	23.0 (17.1)
PTO horsepower at 3200 rpm	HP (kW)	13.7 (10.2)	17.7 (13.2)	19.5 (14.5)	17.7 (13.2)
Displacement	cu.in. (cc)	43.9 (719)	54.8 (898)	61.1 (1001)	54.8 (898)
Fuel tank capacity	ℓ	25			
<b>Drive train</b>		HST, High-Low gear shift (2 forward / reverse)			
Transmission		HST, High-Low gear shift (2 forward / reverse)			
Drive method		4WD			
Brakes		Wet disc			
PTO		Live independent PTO (with hydraulic clutch)			
Rear		STD (540rpm)			
Mid		STD (2500rpm)			
<b>Hydraulics</b>		SAE Category I			
Pump output	ℓ/min	23.5			
3-point hitch		SAE Category I			Optional
Lift capacity @ 24" behind pin	kg	310			
Steering		Hydrostatic Power Steering			
<b>Tyre size</b>		18×8.5–10 / 18×8.5–10 / 18×8.5–10			
Front	Turf/Bar/Industrial	16×7.5–8 / 16×7.5–8 / N.A.		18×8.5–10 / 18×8.5–10 / 18×8.5–10	
Rear	Turf/Bar/Industrial	24×12–12 / 24×12–12 / N.A.		26×12–12 / 26×12–12 / 26×12–12	
<b>Travelling speeds at rated engine rpm (Turf)</b>	Forward	km/h	0–12.5		0–13.5
	Reverse	km/h	0–9.5		0–10.5
<b>Dimensions</b>		2425			
Length with 3-point hitch	mm	2425			2515 w/ Front guard
Width	mm	1120	1145		
Height with ROPS	mm	2080	2110	2190	
Wheelbase	mm	1400			
Ground clearance (front axle)	mm	193	213		
Tread	Front	mm	930		
	Rear	mm	820		
Turning radius (w/o brake)	m	2.3			
Tractor weight (w/ROPS)	kg	606	650	670	712 *2

## BX23S\*\* Backhoe Specifications

Model		BT603
Bucket cylinder digging force	N	8610
Dipperstick cylinder digging force	N	5209
Boom swing mechanism		One cylinder
Shipping weight (with 12" bucket)	kg	275
Transport height	mm	1719
Loading height	mm	1533
Digging depth	mm	1842
Swing pivot to rear axle center line	mm	726
Reach from swing pivot	mm	2612
Bucket rotation	degrees	180
Swing arc	degrees	140
Angle of departure	degrees	20.1

\*SAE J1995 \*\*w/ Front guard, w/ control valve assy

\*\*The loader and backhoe come standard on the BX23S model.

## BX23S\*\* Loader Specifications

Model		LA340
Type		Pin-on
Max. lift height (to bucket pivot pin)	mm	1804
Dumping clearance	mm	1323
Dumping reach at max. lift height	mm	646
Maximum dump angle	degrees	45
Reach with bucket on ground	mm	1392
Bucket rollback angle	degrees	29
Digging depth	mm	125
Bucket width	mm	1219
Rated Operator Load	kg	220
Breakout force (500mm fwd)	N	4389
Raising time / lowering time (w/o load)	second	3.3 / 2.5
Bucket rollback time / dumping time	second	2.3 / 2.7

The company reserves the right to change the above specifications without notice.

This brochure is for descriptive purposes only. Please contact your local Kubota dealer for warranty information.

For your safety, Kubota strongly recommends the use of a Rollover Protective Structure (ROPS) and seat belt in almost all applications.



## Front Loader Specifications

Model Type		LA344 Pin-on	
		BX1880	BX2380/BX2680
Max. lift height (to bucket pivot pin)	mm	1795	1804
Dumping clearance	mm	1316	1323
Dumping reach at max. lift height	mm	642	646
Max. dump angle	degrees	45	
Reach with bucket on ground	mm	1398	1392
Bucket rollback angle	degrees	30	29
Digging depth	mm	134	125
Rated Operator Load	kg	180	
Breakout Force (500mm fwd.)	N	4389	



## GRASS CATCHER

## Mid-Mount Mower Specifications

Model	RCK54-23BX		RCK60B-23BX	
	BX1880/BX2380 BX2680/BX23S		BX2380/BX2680 BX23S	
Type	Side discharge			
Number of blades	3			
Mounting method	Suspended-Linkage		Self Balance	
Cutting width	in. (mm)	54 (1372)	60 (1524)	
Cutting height	in. (mm)	1.0–4.0 (25–102)		
Adjustment of cutting height	1/4" Dial gauge			
Weight	kg	95	115	
Ground clearance in transport position	mm	152		

## Easy-Over Mower Specifications

RCK54D-26BX-1		RCK60D-26BX-1	
BX2380 BX2680	BX23S	BX2380 BX2680	BX23S
Side discharge			
3			
Drive over Suspended-Linkage			
54 (1372)		60 (1524)	
1.0–4.0 (25–102)			
1/4" Dial gauge			
122	117	134	129
152			

\*Not compatible with bar tyres.

### Industrial tyre

(BX2380, BX2680, BX23S only)

### Turf tyre

(All models)

### Bar tyre

(BX1880, BX2380, BX2680 only)



## Kubota Genuine Parts

for maximum  
performance,  
durability and  
safety



©2017 Kubota Corporation

---



**KUBOTA Tractor Australia Pty Ltd**

25-29 Permas Way, Truganina VIC, 3029 Australia  
Freecall: 1800-334-653  
Email: sales@kubota.com.au

**Web Site:** <http://www.kubota.com.au>

**CB Norwood Distributors Ltd**

888 Tremaine Avenue, Palmerston North, 4440 New Zealand  
Tel: 06-356-4920  
Email: info@norwood.co.nz

**Web Site:** <http://www.kubota.co.nz>